

In **Figure 5-2** the gear train has a difference of numbers of teeth of only 1; $z_1 = 30$ and $z_2 = 31$. This results in a reduction ratio of 1/30.

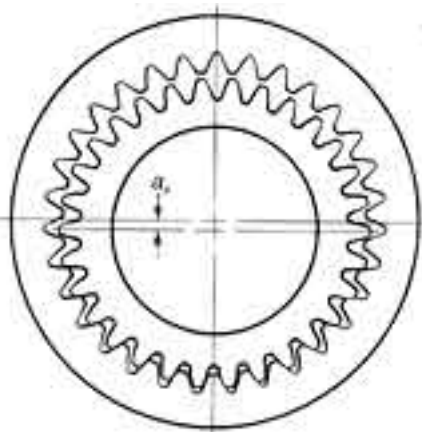

Fig. 5-2 The Meshing of Internal Gear and External Gear in which the Numbers of Teeth Difference is 1
($z_2 - z_1 = 1$)

SECTION 6 HELICAL GEARS

The helical gear differs from the spur gear in that its teeth are twisted along a helical path in the axial direction. It resembles the spur gear in the plane of rotation, but in the axial direction it is as if there were a series of staggered spur gears. See **Figure 6-1**. This design brings forth a number of different features relative to the spur gear, two of the most important being as follows:

1. Tooth strength is improved because of the elongated helical wraparound tooth base support.
2. Contact ratio is increased due to the axial tooth overlap. Helical gears thus tend to have greater load carrying capacity than spur gears of the same size. Spur gears, on the other hand, have a somewhat higher efficiency.

Helical gears are used in two forms:

1. Parallel shaft applications, which is the largest usage.
2. Crossed-helicals (also called spiral or screw gears) for connecting skew shafts, usually at right angles.

6.1 Generation Of The Helical Tooth

The helical tooth form is involute in the plane of rotation and can be developed in a manner similar to that of the spur gear. However, unlike the spur gear which can be viewed essentially as two dimensional, the helical gear must be portrayed in three dimensions to show changing axial features.

Referring to Figure 6-2, there is a base cylinder from which a

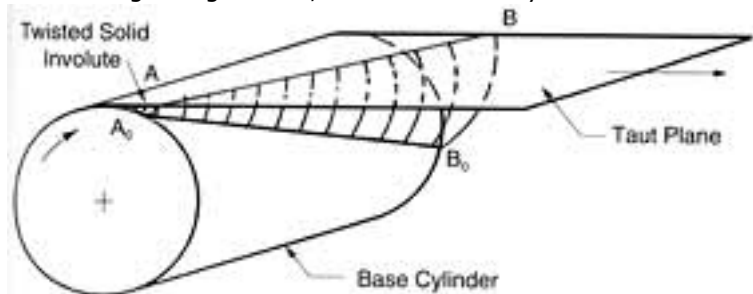

Fig. 6-2 Generation of the Helical Tooth Profile



Fig. 6-1 Helical Gear

taut plane is unwrapped, analogous to the unwinding taut string of the spur gear in **Figure 2-2**. On the plane there is a straight line AB, which when wrapped on the base cylinder has a helical trace A_0B_0 . As the taut plane is unwrapped, any point on the line AB can be visualized as tracing an involute from the base cylinder. Thus, there is an infinite series of involutes generated by line AB, all alike, but displaced in phase along a helix on the base cylinder.

Again, a concept analogous to the spur gear tooth development is to imagine the taut plane being wound from one base cylinder on to another as the base cylinders rotate in opposite directions. The result is the generation of a pair of conjugate helical involutes. If a reverse direction of rotation is assumed and a second tangent plane is arranged so that it crosses the first, a complete involute helicoid tooth is formed.

6.2 Fundamentals Of Helical Teeth

In the plane of rotation, the helical gear tooth is involute and all of the relationships governing spur gears apply to the helical. However, the axial twist of the teeth introduces a helix angle. Since the helix angle varies from the base of the tooth to the outside radius, the helix angle β is defined as the angle between the tangent to the helicoidal tooth at the intersection of the pitch cylinder and the tooth profile, and an element of the pitch cylinder. See **Figure 6-3**.

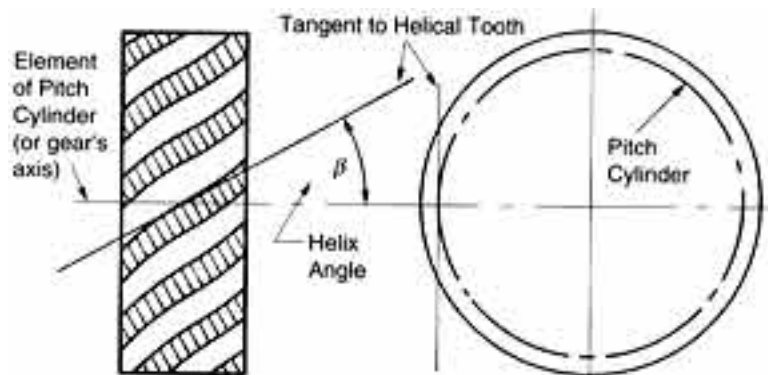

Fig. 6-3 Definition of Helix Angle

The direction of the helical twist is designated as either left or right. The direction is defined by the right-hand rule.

For helical gears, there are two related pitches - one in the plane of rotation and the other in a plane normal to the tooth. In addition, there is an axial pitch.

Referring to **Figure 6-4**, the two circular pitches are defined and related as follows:

$$p_n = p_t \cos \beta = \text{normal circular pitch}$$

The normal circular pitch is less than the transverse radial pitch, p_t in the plane of rotation; the ratio between the two being equal to the cosine of the helix angle.

Consistent with this, the normal module is less than the transverse (radial) module.

The axial pitch of a helical gear, p_x , is the distance between corresponding points of adjacent teeth measured parallel to the gear's axis - see **Figure 6-5**.

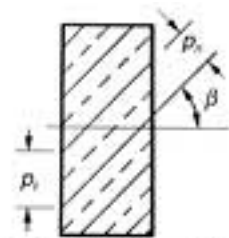

Fig. 6-4 Relationship of Circular Pitches

(6-1)

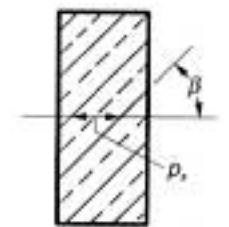

Fig. 6-5 Axial Pitch of a Helical Gear

Axial pitch is related to circular pitch by the expressions:

$$p_x = p_t \cot \beta = \frac{p_n}{\sin \beta} = \text{axial pitch} \quad (6-2)$$

A helical gear such as shown in **Figure 6-6** is a cylindrical gear in which the teeth flank are helicoid. The helix angle in standard pitch circle cylinder is β , and the displacement of one rotation is the lead, L .

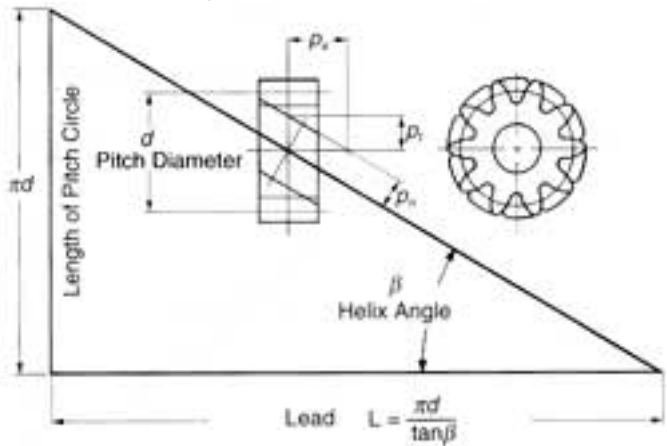

Fig. 6-6 Fundamental Relationship of a Helical Gear (Right-Hand)

The tooth profile of a helical gear is an involute curve from an axial view, or in the plane perpendicular to the axis, the helical gear has two kinds of tooth profiles - one is based on a normal system, the other is based on an axial system.

Circular pitch measured perpendicular to teeth is called normal circular pitch, P_n And p_n , divided by p is then a normal module, m_t

$$m_n = \frac{P_n}{p} \quad (6-3)$$

The tooth profile of a helical gear with applied normal module, m_n , and normal pressure angle α_n belongs to a normal system.

In the axial view, the circular pitch on the standard pitch circle is called the radial circular pitch, P_t And p_t , divided by p is the radial module, m_t .

$$m_t = \frac{P_t}{p} \quad (6-4)$$

6.3 Equivalent Spur Gear

The true involute pitch and involute geometry of a helical gear is in the plane of rotation. However, in the normal plane, looking at one tooth, there is a resemblance to an involute tooth of a pitch corresponding to the normal pitch. However, the shape of the tooth corresponds to a spur gear of a larger number of teeth, the exact value depending on the magnitude of the helix angle.

The geometric basis of deriving the number of teeth in this equivalent tooth form spur gear is given in **Figure 6-7**. The result of the transposed geometry is an equivalent number of teeth, given as:

$$z_v = \frac{z}{\cos^3 \beta} \quad (6-5)$$

This equivalent number is also called a virtual number because this spur gear is imaginary. The value of this number is used in determining helical tooth strength.

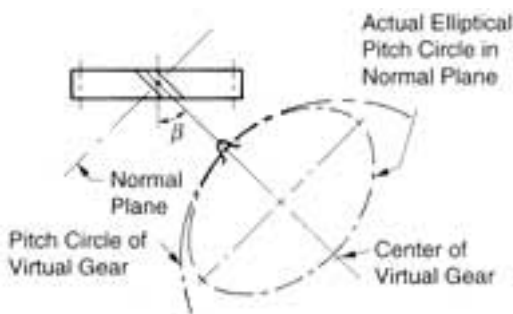

Fig. 6-7 Geometry of Helical Gear's Virtual Number of Teeth

6.4 Helical Gear Pressure Angle

Although, strictly speaking, pressure angle exists only for a gear pair, a nominal pressure angle can be considered for an individual gear.

For the helical gear there is a normal pressure, α_n , angle as well as the usual pressure angle in the plane of rotation, α .

Figure 6-8 shows their relationship, which is expressed as:

$$\tan \alpha = \frac{\tan \alpha_n}{\cos \beta} \quad (6-6)$$

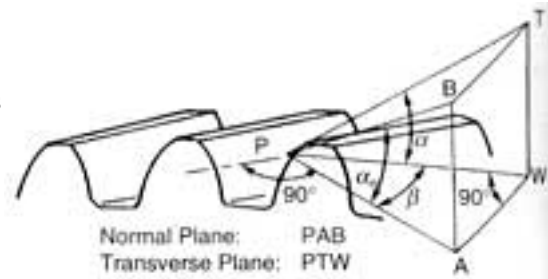

Fig. 6-8 Geometry of Two Pressure Angles

6.5 Importance Of Normal Plane Geometry

Because of the nature of tooth generation with a rack-type hob, a single tool can generate helical gears at all helix angles as well as spur gears. However, this means the normal pitch is the common denominator, and usually is taken as a standard value. Since the true involute features are in the transverse plane, they will differ from the standard normal values. Hence, there is a real need for relating parameters in the two reference planes.

6.6 Helical Tooth Proportions

These follow the same standards as those for spur gears. Addendum, dedendum, whole depth and clearance are the same regardless of whether measured in the plane of rotation or the normal plane. Pressure angle and pitch are usually specified as standard values in the normal plane, but there are times when they are specified as standard in the transverse plane.

6.7 Parallel Shaft Helical Gear Meshes

Fundamental information for the design of gear meshes is as follows:

Helix angle - Both gears of a meshed pair must have the same helix angle. However, the helix direction must be opposite; i.e., a left-hand mates with a right-hand helix.

Pitch diameter - This is given by the same expression as for spur gears, but if the normal module is involved it is a function of the helix angle. The expressions are:

$$d = z m_t = \frac{z}{m_n \cos \beta} \quad (6-7)$$

Center distance - Utilizing **Equation (6-7)**, the center distance of a helical gear mesh is:

$$a = \frac{Z_1 + Z_2}{2 m_n \cos \beta} \quad (6-8)$$

Note that for standard parameters in the normal plane, the center distance will not be a standard value compared to standard spur gears. Further, by manipulating the helix angle, β , the center distance can be adjusted over a wide range of values. Conversely, it is possible:

1. to compensate for significant center distance changes (or errors) without changing the speed ratio between parallel geared shafts; and
2. to alter the speed ratio between parallel geared shafts, without changing the center distance, by manipulating the helix angle along with the numbers of teeth.

6.8 Helical Gear Contact Ratio

The contact ratio of helical gears is enhanced by the axial overlap of the teeth. Thus, the contact ratio is the sum of the transverse contact ratio, calculated in the same manner as for spur gears, and a term involving the axial pitch.

$$\begin{aligned} (\epsilon)_{\text{total}} &= (\epsilon)_{\text{trans}} + (\epsilon)_{\text{axial}} \\ \text{or} & \\ \epsilon_r &= \epsilon_\alpha + \epsilon_\beta \end{aligned} \quad (6-9)$$

Details of contact ratio of helical gearing are given later in a general coverage of the subject; see **SECTION 11.1**.

6.9 Design Considerations

6.9.1 Involute Interference

Helical gears cut with standard normal pressure angles can have considerably higher pressure angles in the plane of rotation - see Equation (6-6) - depending on the helix angle. Therefore, the minimum number of teeth without undercutting can be significantly reduced, and helical gears having very low numbers of teeth without undercutting are feasible.

6.9.2 Normal vs. Radial Module (Pitch)

In the normal system, helical gears can be cut by the same gear hob if module m_n and pressure angle α_n are constant, no matter what the value of helix angle β .

It is not that simple in the radial system. The gear hob design must be altered in accordance with the changing of helix angle β even when the module m , and the pressure angle α_t , are the same.

Obviously, the manufacturing of helical gears is easier with the normal system than with the radial system in the plane perpendicular to the axis.

6.10 Helical Gear Calculations

6.10.1 Normal System Helical Gear

In the normal system, the calculation of a profile shifted helical gear, the working pitch diameter d_w and working pressure angle α_{wt} in the axial system is done per **Equations (6-10)**. That is because meshing of the helical gears in the axial direction is just like spur gears and the calculation is similar.

$$\begin{aligned} d_{w1} &= 2a_x \frac{z_1}{z_1 + z_2} \\ d_{w2} &= 2a_x \frac{z_2}{z_1 + z_2} \\ \alpha_{wt} &= \cos^{-1} \left(\frac{d_{b1} + d_{b2}}{2a_x} \right) \end{aligned} \quad (6-10)$$

Table 6-1 shows the calculation of profile shifted helical gears in the normal system. If normal coefficients of profile shift x_{n1} , x_{n2} are zero, they become standard gears.

If center distance, a_x is given, the normal coefficient of profile shift x_{n1} and x_{n2} can be calculated from **Table 6-2**. These are the inverse equations from items 4 to 10 of **Table 6-1**.

Table 6-1 The Calculation of a Profile Shifted Helical Gear in the Normal System (1)

No.	Item	Symbol	Formula	Example	
				Pinion	Gear
1	Normal Module	m_n		3	
2	Normal Pressure Angle	α_n		20°	
3	Helix Angle	β		30°	
4	Number of Teeth & Helical Hand	z_1, z_2		12 (L)	60 (R)
5	Radial Pressure Angle	α_t	$\tan^{-1} \left(\frac{\tan \alpha_n}{\cos \beta} \right)$	22.79588°	
6	Normal Coefficient of Profile Shift	x_{n1}, x_{n2}		0.09809	0
7	Involute Function α_{wt}	$\text{inv } \alpha_{wt}$	$2 \tan \alpha_n \left(\frac{x_{n1} + x_{n2}}{z_1 + z_2} \right) + \text{inv } \alpha_t$	0.023405	
8	Radial Working Pressure Angle	α_{wt}	Find from Involute Function Table	23.1126°	
9	Center Distance Increment Factor	y	$\frac{z_1 + z_2}{2 \cos \beta} \left(\frac{\cos \alpha_t}{\cos \alpha_{wt}} - 1 \right)$	0.09744	
10	Center Distance	a_x	$\left(\frac{z_1 + z_2}{2 \cos \beta} + y \right) m_n$	125.000	
11	Standard Pitch Diameter	d	$\frac{z m_n}{\cos \beta}$	41.569	207.846
12	Base Diameter	d_b	$d \cos \alpha_t$	38.322	191.611
13	Working Pitch Diameter	d_w	$\frac{d_b}{\cos \alpha_{wt}}$	41.667	208.333
14	Addendum	h_{a1} h_{a2}	$(1 + y - x_{n2}) m_n$ $(1 + y - x_{n1}) m_n$	3.292	2.998
15	Whole Depth	h	$[2.25 + y - (x_{n1} + x_{n2})] m_n$	6.748	
16	Outside Diameter	d_a	$d + 2 h_a$	48.153	213.842
17	Root Diameter	d_f	$d_a - 2 h$	34.657	200.346

Table 6-2 The Calculations of a Profile Shifted Helical Gear in the Normal System (2)

No.	Item	Symbol	Formula	Example
1	Center Distance	a_x		125
2	Center Distance Increment Factor	y	$\frac{a_x}{m_n} - \frac{z_1 + z_2}{2 \cos \beta}$	0.097447
3	Radial Working Pressure Angle	α_{wt}	$\cos^{-1} \left[\frac{(z_1 + z_2) \cos \alpha_t}{(z_1 + z_2) + 2y \cos \beta} \right]$	23.1126°
4	Sum of Coefficient of Profile Shift	$x_{n1} + x_{n2}$	$\frac{(z_1 + z_2)(\text{inv } \alpha_{wt} - \text{inv } \alpha_t)}{2 \tan \alpha_n}$	0.09809
5	Normal Coefficient of Profile Shift	x_{n1}, x_{n2}		0.09809 0

The transformation from a normal system to a radial system is accomplished by the following equations:

$$\left. \begin{aligned} x_r &= x_n \cos \beta \\ m_r &= \frac{m_n}{\cos \beta} \\ \alpha_r &= \tan^{-1} \left(\frac{\tan \alpha_n}{\cos \beta} \right) \end{aligned} \right\} \quad (6-11)$$

6.10.2 Radial System Helical Gear

Table 6-3 shows the calculation of profile shifted helical gears in a radial system. They become standard if $x_{11} = x_{12} = 0$.

Table 6-4 presents the inverse calculation of items 5 to 9 of **Table 6-3**.

The transformation from a radial to a normal system is described by the following equations:

$$\left. \begin{aligned} x_n &= \frac{x_r}{\cos \beta} \\ m_n &= m_r \cos \beta \\ \alpha_n &= \tan^{-1} (\tan \alpha_r \cos \beta) \end{aligned} \right\} \quad (6-12)$$

6.10.3 Sunderland Double Helical Gear

A representative application of radial system is a double helical gear, or herringbone gear, made with the Sunderland machine. The radial pressure angle, α_r and helix angle, β , are specified as 20° and 22.5° , respectively. The only differences from the radial system equations of **Table 6-3** are those for addendum and whole depth. **Table 6-5** presents equations for a Sunderland gear.

6.10.4 Helical Rack

Viewed in the normal direction, the meshing of a helical rack and gear is the same as a spur gear and rack. **Table 6-6** presents the calculation examples for a mated helical rack with normal module and normal pressure angle standard values. Similarly, **Table 6-7** presents examples for a helical rack in the radial system (i.e., perpendicular to gear axis).

Table 6-3 The Calculation of a Profile Shifted Helical Gear in the Radial System (1)

No.	Item	Symbol	Formula	Example	
				Pinion	Gear
1	Radial Module	m_r		3	
2	Radial Pressure Angle	α_r		20°	
3	Helix Angle	β		30°	
4	Number of Teeth & Helical Hand	z_1, z_2		12 (L)	60 (R)
5	Radial Coefficient of Profile Shift	x_{r1}, x_{r2}		0.34462	0
6	Involute Function α_{wt}	$inv \alpha_{wt}$	$2 \tan \alpha_r \left(\frac{x_{r1} + x_{r2}}{z_1 + z_2} \right) + inv \alpha_r$	0.0183886	
7	Radial Working Pressure Angle	α_{wt}	Find from Involute Function Table	21.3975°	
8	Center Distance Increment Factor	y	$\frac{z_1 + z_2}{2} \left(\frac{\cos \alpha_r}{\cos \alpha_{wt}} - 1 \right)$	0.33333	
9	Center Distance	a_x	$\left(\frac{z_1 + z_2}{2} + y \right) m_r$	109.0000	
10	Standard Pitch Diameter	d	$z m_r$	36.000	180.000
11	Base Diameter	d_b	$d \cos \alpha_r$	33.8289	169.1447
12	Working Pitch Diameter	d_w	$\frac{d_b}{\cos \alpha_{wt}}$	36.3333	181.6667
13	Addendum	h_{a1} h_{a2}	$(1 + y - x_{r2}) m_r$ $(1 + y - x_{r1}) m_r$	4.000	2.966
14	Whole Depth	h	$[2.25 + y - (x_{r1} + x_{r2})] m_r$	6.716	
15	Outside Diameter	d_a	$d + 2 h_a$	44.000	185.932
16	Root Diameter	d_f	$d_a - 2 h$	30.568	172.500

Table 6-4 The Calculation of a Shifted Helical Gear in the Radial System (2)

No.	Item	Symbol	Formula	
1	Center Distance	a_x		109
2	Center Distance Increment Factor	y	$\frac{a_x}{m_r} - \frac{z_1 + z_2}{2}$	0.33333
3	Radial Working Pressure Angle	α_{wt}	$\cos^{-1} \left[\frac{(z_1 + z_2) \cos \alpha_r}{(z_1 + z_2) + 2y} \right]$	21.39752°
4	Sum of Coefficient of Profile Shift	$x_{r1} + x_{r2}$	$\frac{(z_1 + z_2)(inv \alpha_{wt} - inv \alpha_r)}{2 \tan \alpha_n}$	0.34462
5	Normal Coefficient of Profile Shift	x_{r1}, x_{r2}		0.34462 0

Table 6-5 The Calculation of a Double Helical Gear of SUNDERLAND Tooth Profile

No.	Item	Symbol	Formula	Example	
				Pinion	Gear
1	Radial Module	m_r		3	
2	Radial Pressure Angle	α_r		20°	
3	Helix Angle	β		22.5°	
4	Number of Teeth	z_1, z_2		12	60
5	Radial Coefficient of Profile Shift	x_{r1}, x_{r2}		0.34462	0
6	Involute Function α_{wt}	$inv \alpha_{wt}$	$2 \tan \alpha_r \left(\frac{x_{r1} + x_{r2}}{z_1 + z_2} \right) + inv \alpha_r$	0.0183886	
7	Radial Working Pressure Angle	α_{wt}	Find from Involute Function Table	21.3975°	
8	Center Distance Increment Factor	y	$\frac{z_1 + z_2}{2} \left(\frac{\cos \alpha_r}{\cos \alpha_{wt}} - 1 \right)$	0.33333	
9	Center Distance	a_s	$\left(\frac{z_1 + z_2}{2} + y \right) m_r$	109.0000	
10	Standard Pitch Diameter	d	$z m_r$	36.000	180.000
11	Base Diameter	d_b	$d \cos \alpha_r$	33.8289	169.1447
12	Working Pitch Diameter	d_w	$\frac{d_b}{\cos \alpha_{wt}}$	36.3333	181.6667
13	Addendum	h_{a1}, h_{a2}	$(0.8796 + y - x_{r1}) m_r$ $(0.8796 + y - x_{r2}) m_r$	3.639	2.605
14	Whole Depth	h	$[1.8849 + y - (x_{r1} + x_{r2})] m_r$	5.621	
15	Outside Diameter	d_a	$d + 2 h_a$	43.278	185.210
16	Root Diameter	d_f	$d_a - 2 h$	32.036	173.968

Table 6-6 The Calculation of a Helical Rack in the Normal System

No.	Item	Symbol	Formula	Example	
				Gear	Rack
1	Normal Module	m_n		2.5	
2	Normal Pressure Angle	α_n		20°	
3	Helix Angle	β		10° 57' 49"	
4	Number of Teeth & Helical Hand	z		20 (R)	– (L)
5	Normal Coefficient of Profile Shift	x_n		0	–
6	Pitch Line Height	H		–	27.5
7	Radial Pressure Angle	α_r	$\tan^{-1} \left(\frac{\tan \alpha_n}{\cos \beta} \right)$	20.34160°	
8	Mounting Distance	a_s	$\frac{z m_n}{2 \cos \beta} + H + x_n m_n$	52.965	
9	Pitch Diameter	d	$\frac{z m_n}{\cos \beta}$	50.92956	–
10	Base Diameter	d_b	$d \cos \alpha_r$	47.75343	–
11	Addendum	h_a	$m_n (1 + x_n)$	2.500	2.500
12	Whole Depth	h	$2.25 m_n$	5.625	
13	Outside Diameter	d_a	$d + 2 h_a$	55.929	–
14	Root Diameter	d_f	$d_a - 2 h$	44.679	–

Table 6-7 The Calculation of a Helical Rack in the Radial System

No.	Item	Symbol	Formula	Example	
				Gear	Rack
1	Radial Module	m_r		2.5	
2	Radial Pressure Angle	α_r		20°	
3	Helix Angle	β		10° 57' 49"	
4	Number of Teeth & Helical Hand	z		20 (R)	– (L)
5	Radial Coefficient of Profile Shift	x_r		0	–
6	Pitch Line Height	H		–	27.5
7	Mounting Distance	a_s	$\frac{z m_r}{2} + H + x_r m_r$	52.500	
8	Pitch Diameter	d	$z m_r$	50.000	–
9	Base Diameter	d_b	$d \cos \alpha_r$	46.98463	–
10	Addendum	h_a	$m_r (1 + x_r)$	2.500	2.500
11	Whole Depth	h	$2.25 m_r$	5.625	
12	Outside Diameter	d_a	$d + 2 h_a$	55.000	–
13	Root Diameter	d_f	$d_a - 2 h$	43.750	–